

INDOOR UNIT

RSUB-61-K

CODE OPTIONS

CSD-1 Manual Reset LWCO

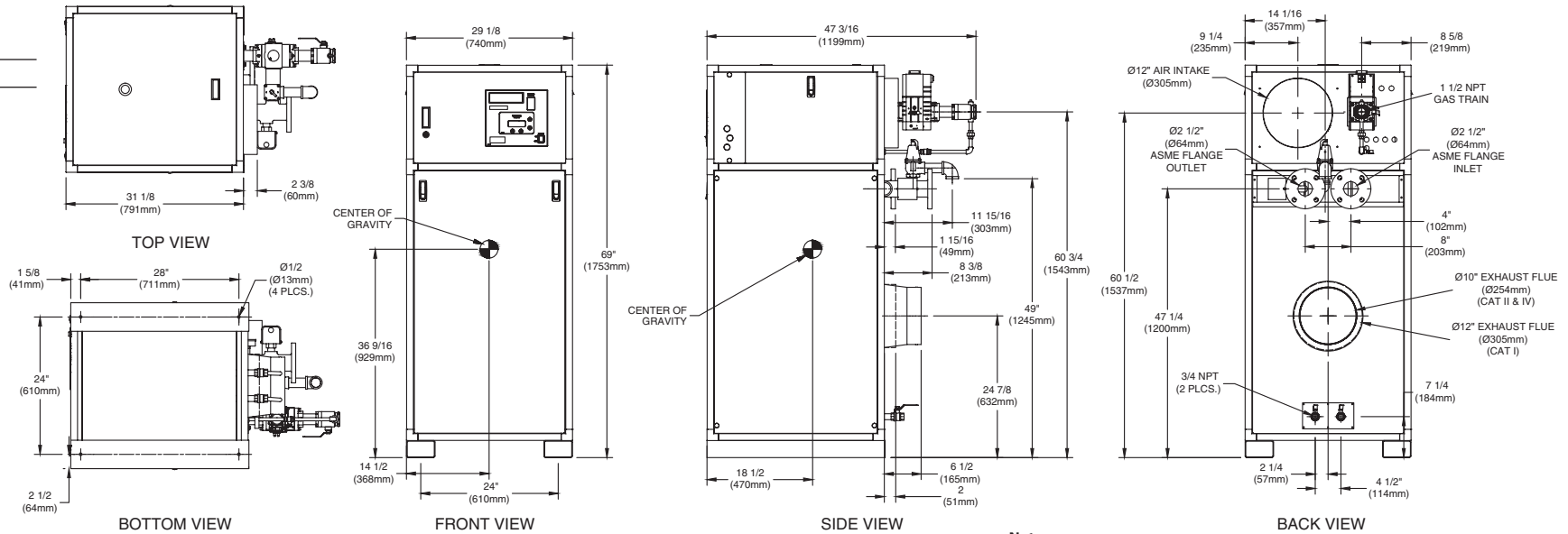

Notes:

1. Dimensions are approximate and should not be used to "rough-in" equipment.
2. Dimensions are subject to change without notice.

BOILER CERTIFIED RATINGS & CAPACITIES

Fuel Type	Natural/Propane Gas	Boiler FLA	11.3*
Input BTU/hr.	2,000,000 / 586 kW	Min. Gas Pressure Required	2" W.C.**
Output BTU/hr.	1,703,999 / 499 kW	Max. Gas Pressure Allowed	14" W.C.
Electrical Requirements	(L1, NEU, GND) 120VAC/1 ph/60 hz	Operating Weight	1003 lbs. / 455 kg.

BOILER TEMPERATURE RISE / PRESSURE DROP

25°F / 13.9°C				30°F / 16.7°C				35°F / 19.4°C			
Flow Rate		Pressure Drop		Flow Rate		Pressure Drop		Flow Rate		Pressure Drop	
GPM	L/s	Ft	kPa	GPM	L/s	Ft	kPa	GPM	L/s	Ft	kPa
136.3	8.6	5.41	15.9	113.6	7.2	3.86	11.4	97.4	6.1	2.90	8.5

BOILER / WATER HEATER TRIM & CONTROLS

Main Gas Valve	Dungs MBC-SE	Air Switch	Cleveland NS2
Firing Valve	1 1/2"	Blower Motor	Fasco 1 hp - FLA 3.0
Ignition Control	Honeywell RM7895C	Relief Valve - MW	3/4" x 3/4" set @ 125 psi
Operating Control	HeatNet®	Relief Valve - MB	1" x 1 1/4" set @ 50 psi
High Limit	Jumo	Flow Switch	TACO
Main Ball Valve	1 1/2"	Pilot Regulator	White-Rodgers 25M

WATER HEATER HOURLY RECOVERY CAPACITY (GPH & LPH)

40°F	22°C	60°F	33°C	80°F	44°C	100°F	56°C	120°F	67°C	140°F	78°C
4922	18605	3281	12403	2461	9303	1969	7442	1641	6202	1406	5316

Futera III 2000 model water heater not available for sale in Canada due to NRCan Regulations.

A.S.M.E.

ASME Sect IV Htg Surface	215.98 Sq. Ft. / 20.06 Sq. M.	Design Data	Max. 160 psig & 250°F
Water Volume	5.7 gal / 21.58 Liters		

* Add circulator amps.

** For incoming gas pressures lower than 2" W.C. natural or propane, consult factory.

REP FIRM _____
 SUBMITTED BY _____
 JOB NAME _____
 ARCHITECT _____
 ENGINEER _____
 CONTRACTOR _____
 DATE _____

FUTERA III 2000

Category I, II or IV Appliance

(see Installation and Operation Manual for venting information)



A Division of Mestek, Inc.
 Westfield, MA 01085
 (413) 568-9571

OUTDOOR UNIT

RSUB-116-B

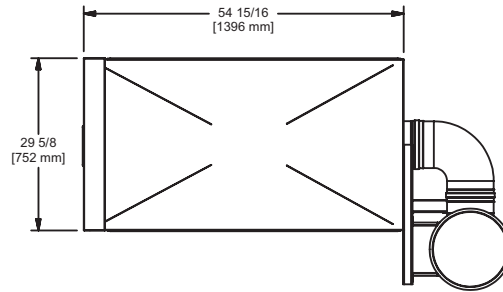

TOP VIEW

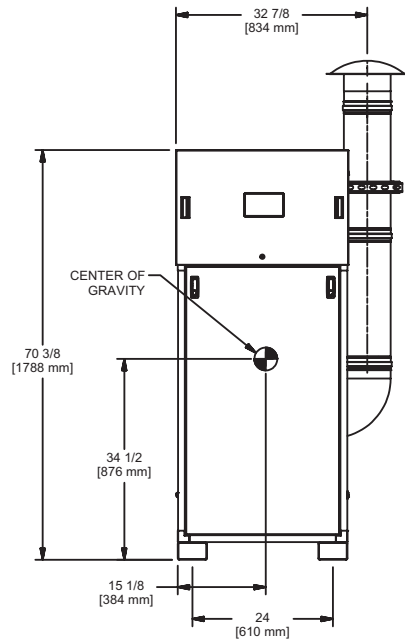

FRONT VIEW

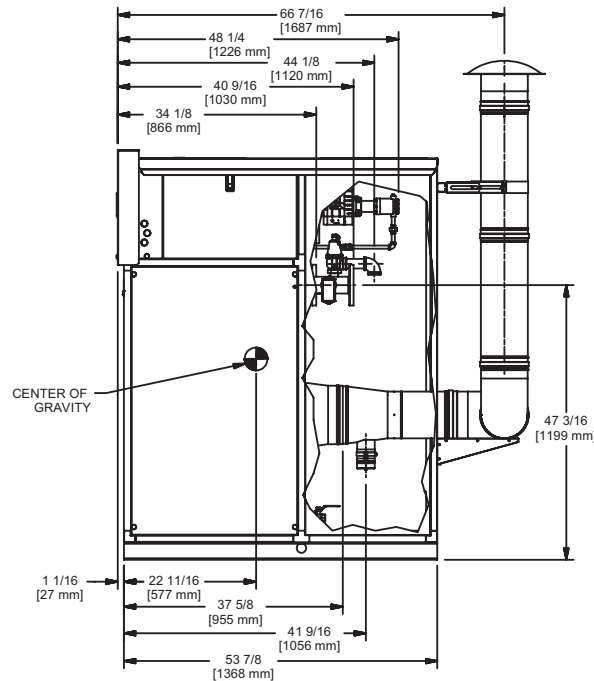

SIDE VIEW

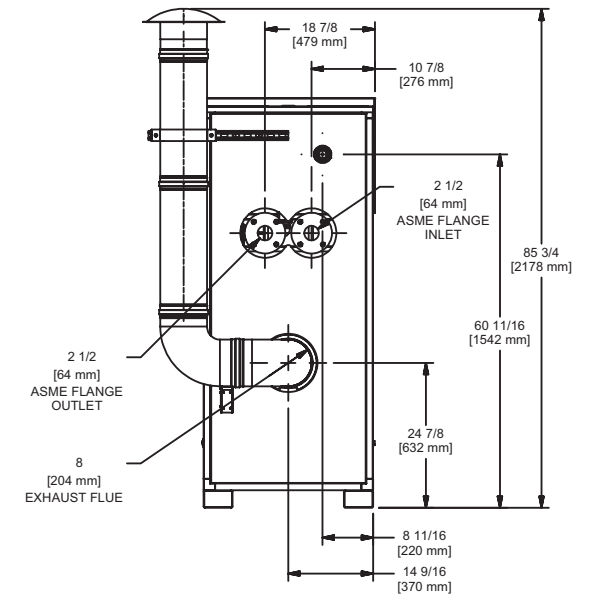

BACK VIEW

FUTERA III 2000

Notes:

1. Dimensions are approximate and should not be used to "rough-in" equipment.
2. Dimensions are subject to change without notice.